

**FRANKLINWH**

# aGate

## Intelligent energy management system

The aGate serves as the controller for all home power sources by interconnecting solar, grid, batteries, and a standby generator to supply electricity to the home. It seamlessly transitions the home supply from grid power to backup power so that always-on appliances, such as the refrigerator and network router, will not be affected when the grid goes down.

The aGate can be installed at the service entrance, connected to the main load center, or used as a load center.



### Robust

- ✓ Micro-grid interconnect device (MID)
- ✓ EMS Integrated PV and grid metering
- ✓ UL1741 certified PCS function & 280A busbar to avoid Main Panel Upgrades
- ✓ 12-year limited warranty



### Hassle-free

- ✓ Precise control of electricity usage through Smart Circuits Module
- ✓ Standby generator integration via generator module
- ✓ Remarkable black start function ensures battery charge after a prolonged outage or extended trip
- ✓ Vehicle to loads (V2L) function to power essential home appliances during an emergency
- ✓ Commissioning through the aGate Wifi hotspot or Bluetooth



### Flexible

- ✓ Compatible with micro and string solar inverter
- ✓ Indoor and outdoor / wall-mounted



### Easy installation

- ✓ Built-in design Smart Circuits and Generator Modules
- ✓ Conduit entry options from the bottom, left, or right

PERFORMANCE SPECIFICATIONS

Model Number	aGate X
Coupling	AC-coupled
Nominal AC Voltage	120 / 208 V, 120 / 240 V, 60 Hz
Phase	2 W+N+PE
aPower Over Current Protection Device	125 A Max
Solar Input Over Current Protection Device	80 A Max
Backup Load Port Over Current Protection Device	200 A Max
Generator Over Current Protection Device <sup>1</sup>	200 A Max
Smart Circuits Over Current Protection Device <sup>2</sup>	Opt. a 1 × 80 A Max @ 208 V / 240 V & 1 × 50 A Max @ 208 V / 240 V Opt. b 1 × 80 A Max @ 208 V / 240 V & 2 × 50 A Max @ 120 V
Maximum Supply Fault Current	22 kA
Busbar Rating	280 A
Work Modes	Self-Consumption, Time of Use, Emergency Backup
Communications	Ethernet / 4G / Wifi / Bluetooth
User Interface	FranklinWH App
Warranty	12-year limited

COMPLIANCE INFORMATION

Certifications	UL 1741, UL 1741 PCS, UL 67, UL 869A, UL 916, CAN / CSA C22.2 No. 107.1-16, CSA C22.2 No. 29, CSA C22.2 No. 0.19
Seismic	AC 156, OSHPD, IEEE 693-2005 (high)
Environmental	California Proposition 65 RoHS Directive 2011 / EU
Emissions	FCC Part 15 Class B, ICES 003

Franklin Home Power Solution

Whole Home Backup

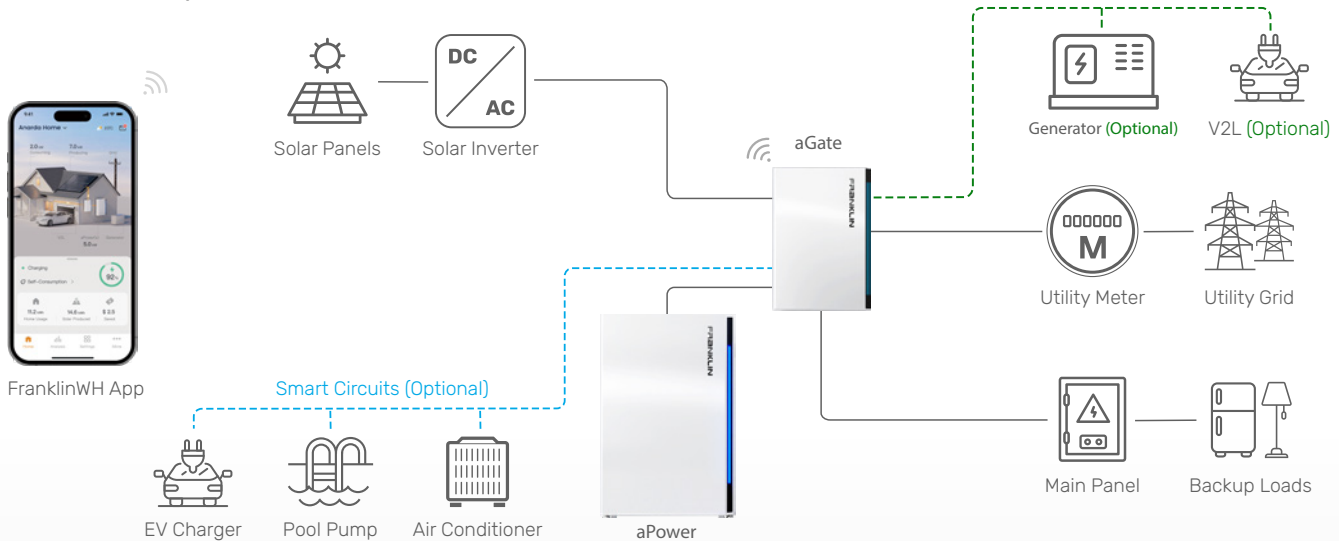

Address: 1731 Technology Dr., Suite 530 San Jose, CA 95110 Telephone: +1 888-837-2655 Email: info@franklinwh.com Website: www.franklinwh.com

Copyright 2024 FranklinWH Energy Storage Inc. All rights reserved. The Franklin logo, FranklinWH, and other trademarks or service names are the trademarks of FranklinWH Energy Storage Inc. The document is for informational purposes only, data subject to change. 2024-10-23



MECHANICAL SPECIFICATIONS

Dimensions (H x W x D)	31.5 in x 21.7 in x 6.3 in (800 mm x 550 mm x 160 mm)
Weight	38.6 lb (17.5 kg)
Mounting	Wall mount

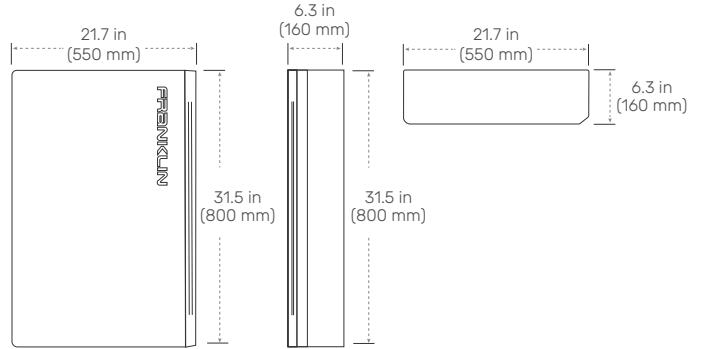

1. Generator Module is optional.
2. Smart Circuit Module is optional.

ENVIRONMENTAL SPECIFICATIONS

Enclosure Type	NEMA 3R
Operating Temperature	-4°F to 122°F (-20°C to 50°C)
Operating Humidity (RH)	Up to 100% RH, condensing
Altitude	Maximum 9,843 ft (3,000 m)
Environment	Indoor and outdoor rated